

# Standard Operating Procedures

## Cupertino Amateur Radio Emergency Service

### Part 1 Overview

#### Contents

1	Introduction .....	2
1.1	Overview.....	2
1.2	Intended Audience .....	2
1.3	How to use this plan .....	2
1.4	Revisions.....	2
2	Organization.....	3
2.1	Charter.....	3
2.2	Organization .....	4
2.3	Roles & Responsibilities.....	6
2.4	DSWVP and City Insurance .....	8
2.5	Affiliations.....	9
3	City Hazards .....	11
3.1	Introduction.....	11
3.2	Seismic Hazard – Earthquakes .....	11
3.3	Flood Hazard from Rain Storms.....	12
3.4	Flooding Hazard from Dam Failure .....	13
3.5	Wildland Fire Hazard .....	14
4	Overview of Operations .....	15
4.1	Introduction.....	15
4.2	Standing Orders.....	15
4.3	Operational Phases.....	15
5	Served Agencies .....	19
5.1	Introduction.....	19
5.2	City of Cupertino.....	19
5.3	Santa Clara County Fire Department.....	21
5.4	Cupertino Sanitary District .....	22
5.5	San Jose Water Company .....	23

# 1 Introduction

The following are the roles and responsibilities for CARES members during a response.

---

## 1.1 Overview

The purpose of the Cupertino Amateur Radio Emergency Service (CARES) Standard Operating Procedure (SOP) is to describe how CARES will operate in an emergency to support the City of Cupertino, other identified local agencies, and city neighborhoods.

This document is intended to assist CARES emergency responders with elements of emergency planning concepts that other organizations have identified as necessary for a useful and effective emergency response organization.

This document is not inclusive of all topics that could be addressed in an emergency plan. Additional information may be required and, when known and available, will be included as attachments to this document.

While the SOP does not intend to be prescriptive, it is written as a starting point for preparing for and executing a response in the event CARES is called on. This document attempts to define who does what, when, where, and how to prepare for, respond to, and recover from the effects of emergencies and disasters.

---

## 1.2 Intended Audience

This document is for use by several groups. CARES members will use it as the basis for describing who we are and what we do. The SOP will also provide CARES members with guidelines, procedures, and policies on how we prepare and respond when activated. It is also an integral part of the CARES Training and Certification Plan.

The SOP is also used by emergency preparedness personnel in the City of Cupertino and other served agencies and organizations to understand the CARES organization, its capabilities, and how CARES integrates and will be coordinated with their existing emergency policies and procedures.

---

## 1.3 How to use this plan

The SOP presents a variety of information useful to all levels in the CARES organization. In the event of an emergency, this document will be used as the foundation of the operating procedures that will guide CARES members during a response.

---

## 1.4 Revisions

To ensure the information remains relevant, accurate, and up-to-date, CARES will review the plan on an annual basis. Changes to this document (either individual pages or in its entirety) will then be distributed to all members and served agencies.

## 2 Organization

---

### 2.1 Charter

The CARES organization was formed to serve the public. It is a volunteer organization made up of FCC-licensed amateur radio operators who live, work, or have a vested interest in Cupertino, and have voluntarily registered their qualifications and equipment for communications duty in the public service when disaster strikes.

#### 2.1.1 Authority

In the event of a declared disaster, CARES operates under the authority and direction of the Director of Emergency Management, City of Cupertino.

#### 2.1.2 Operational Risks

Like most cities, Cupertino faces several operational risks that would adversely impact the city or its residents. These risks include (but are not limited to):

- Emergencies occurring outside of regular working hours may result in a shortage of city staff (who may live outside the city) to immediately handle an emergency.
- Resources to deliver city services during a disaster may be insufficient to handle a potentially overwhelming community need.
- Inadequate or incomplete damage and casualty assessments from Cupertino neighborhoods will hamper a quick and proper response by the City and its contract service providers.
- The commercial communications infrastructure may be unreliable or unavailable during a disaster, thereby potentially overloading the City's trunk radio system.
- The city or other agencies and functions may require temporary flexible communication to remain viable.

In the above cases, the two common, underlying elements are resources and communications.

#### 2.1.3 Mission

The mission of the Cupertino Amateur Radio Emergency Service is to recruit, maintain, and train Amateur Radio volunteers capable of providing professional emergency communications, increasing the City's emergency response effectiveness, and speeding the recovery.

#### 2.1.4 Objectives

The basic objectives CARES pursues are:

- Planning: understand the risks to, and needs of the city, and align our activities to address these needs.
- Preparedness: that the necessary personnel, training, equipment, and procedures are in place and exercised.
- Response: provide backup and emergency communications to our city and served agencies in times of need.

#### 2.1.5 Response Area

CARES will respond to all incorporated and incorporated areas of Cupertino.

As required by the city, CARES will automatically initiate a Mutual Aid response to any Santa Clara County unincorporated area that is either within or adjacent to the City's jurisdictional boundaries. These areas are considered to be within the City's Sphere of Influence.

In the event of a CARES or City response to a surrounding or adjacent unincorporated area, the City will notify the Santa Clara County Office of Emergency Services or Emergency Operations Center.

## 2.2 Organization

### 2.2.1 CARES Structure

At any given time, CARES operates under one of two organization models.

- During Preparedness Operations (when CARES is not activated), CARES focuses on preparedness activities including training, drills, exercises, recruiting, and relationship management.
- During Response Operations (when CARES is activated), CARES supports the emergency response and needs as determined by the City's Planning/ Intelligence Section Chief.

These two models are shown in the following organization charts. Note that the CARES organization structure will change as its needs, and those of its served agencies, change.

#### CARES Preparedness Organization

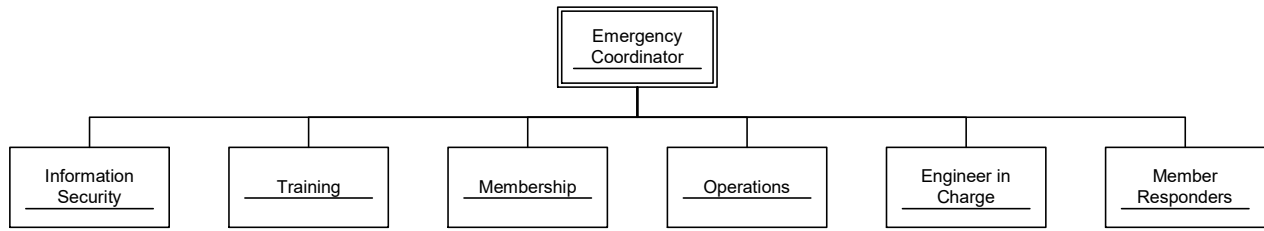

#### CARES Emergency Response Organization

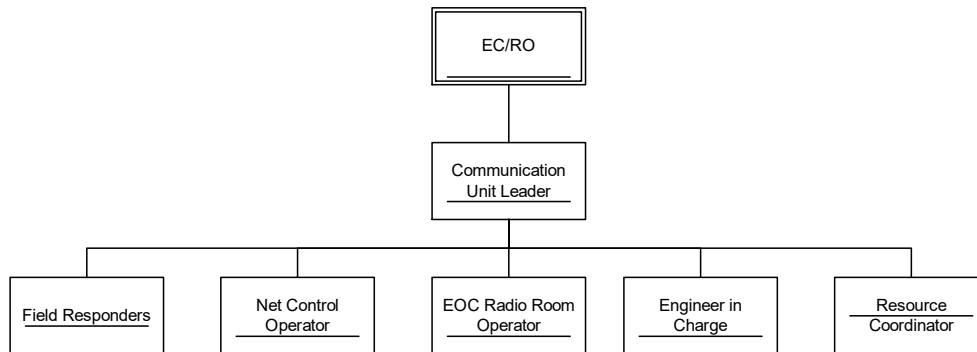

## 2.2.2 City Alignment

The City of Cupertino uses the California Standardized Emergency Management System (SEMS) Incident Command System (ICS) as the primary emergency management response structure for emergency and disaster response operations.

This structure includes the following organization sections:

- **Management Section:** provides the overall direction and sets priorities for resources before and during a disaster. It establishes the emergency policies, and oversees the response for an activation, and deactivation after a disaster.
- **Operations Section:** implements the priorities established by the management section.
- **Planning/Intelligence Section:** collects, evaluates, and disseminates information, develops action plans, maintains documentation, and identifies any potential future emergency response concerns.
- **Logistics Section:** obtains personnel, equipment, and material needed to support the emergency response.
- **Finance/Administration** tracks all costs related to the operation.

During an emergency, CARES reports into the City's Planning/Intelligence Section because of our information gathering and delivery capability.

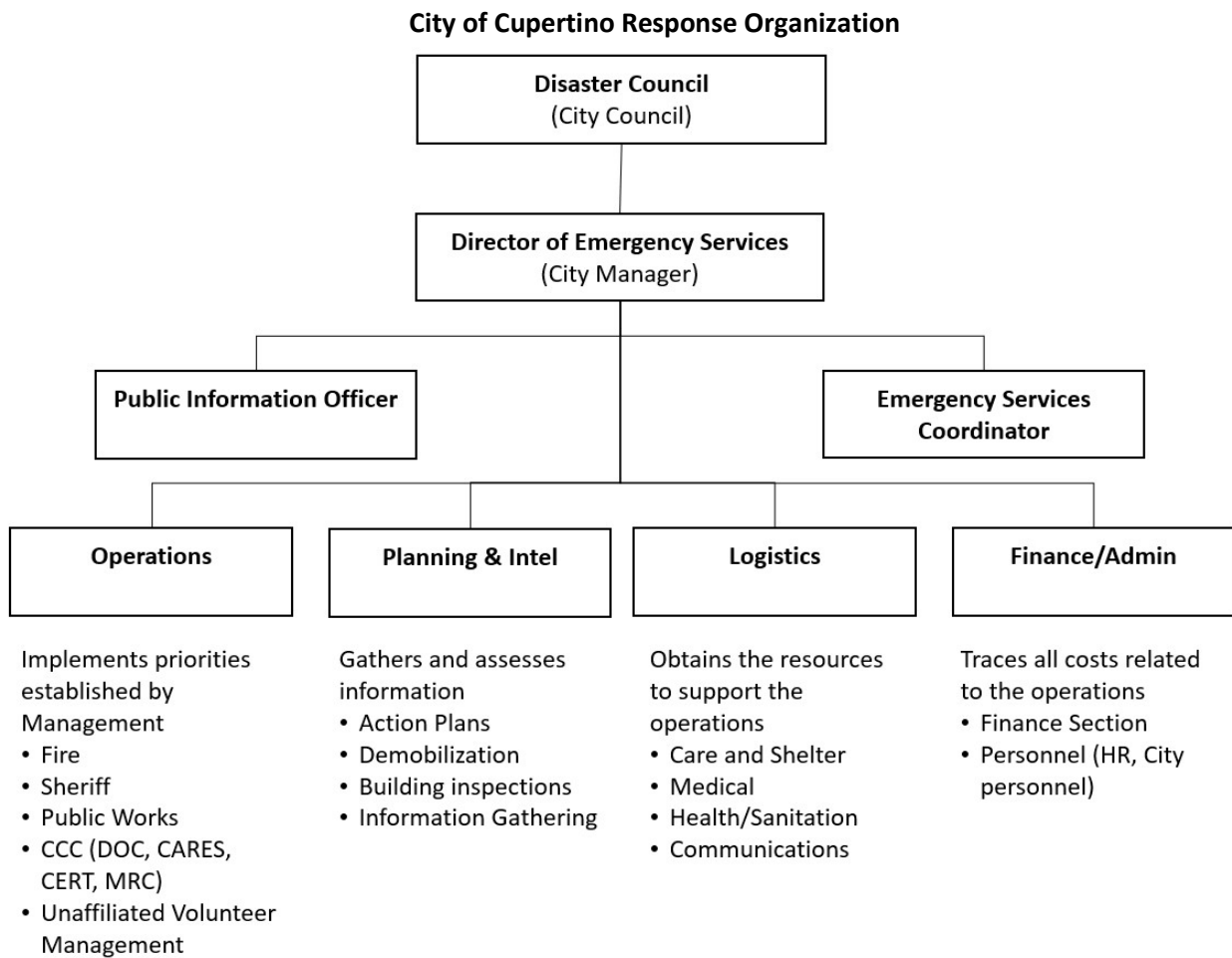

---

## 2.3 Roles & Responsibilities

This section describes the different roles that need to be filled to ensure CARES can carry out its mission.

### 2.3.1 Emergency Coordinator/Radio Officer (EC/RO)

The EC/RO is responsible for all ARES and RACES activities in Cupertino and reports to the Planning/Intelligence Section Chief during an emergency.

The EC/RO fills two positions: (a) the EC aspect of the job is an ARES position appointed by the ARRL Section Manager, and (ii) the RO portion of the job is a RACES position appointed by the City (see Section 2.4 “Affiliations,” for a description of ARES and RACES).

In CARES, the EC/RO position is typically referred to as the Emergency Coordinator, or EC.

The Cupertino EC/RO is responsible for:

- Accomplishing our mission:
  - Promotes and enhances CARES for the public benefit as a voluntary, non-commercial communications service.
  - Builds viable working relationships with the City of Cupertino and Served Agencies.
  - Establishes emergency communication plans and procedures.
  - Evaluates the communications needs of the city and the Served Agencies, and responds quickly to those needs during an emergency.
  - Coordinates the CARES response during an emergency activation for the City of Cupertino and Served Agencies.
  - Assumes the overall responsibility for emergency response and performance of the CARES organization.
  - Attends Santa Clara County EC Council meetings to stay current on County operational issues.
- Developing our people:
  - Ensures that CARES responders receive the training necessary to be successful in executing the CARES mission.
  - Approves training, organization, and emergency participation activities of interested amateurs working in support of the city and agencies.
  - Provides a sense of purpose and contribution.
- Building organizational leadership.

### 2.3.2 Assistant EC/Députa RO (AEC/DRO)

AEC/DROs are appointed by the EC/RO to perform specific tasks on the CARES emergency management staff. When necessary, additional AEC/DROs may be named on an ad hoc basis.

In CARES, an AEC/DRO position is typically referred to as an AEC.

The AEC/DROs are responsible for the following:

- Fills key staff positions within the CARES organization
- Develops cross-operational relationships with other Cupertino volunteer community in specific areas of focus (training, membership, operations)
- Assumes the role of acting EC/RO when the EC/RO is out of the area
- Attends Santa Clara County EC Council meetings to stay current on County operational issues

### 2.3.3 Emergency Responder

An Emergency Responder is a volunteer whose primary responsibility is to report for duty when required, requested, or compelled to do so. A responder is trained, equipped, and physically prepared to perform the responder role.

While there are multiple response locations, it is important that responders are prepared to handle a wide variety of different scenarios. A responder may go to the City EOC, a City ARC, a shelter, a neighborhood, or some other field assignment.

### 2.3.4 Staff Positions

No one person can make CARES work. For the organization to be successful in its mission, CARES must rely on the volunteer efforts and contributions of its members to assume specific roles and responsibilities needed by the organization. The following positions are staffed within CARES:

#### **Operations Officer**

The Operations Officer is responsible for the following:

- Reviews and revise current SOPs
- Working with Training Officer, plans and conducts drills and exercises; implements training in operational aspects of organization (SEMS, ICS, Event Planning, etc.)
- Working with the Chief Engineer makes recommendations for equipment and facility improvements
- Maintains contact with Cupertino Emergency Services Coordinator to understand city needs
- Assists and mentors other CARES members in planning and implementing non-emergency activations

Recommended requirements for the position:

- Completed IS-700, National Incident Management System
- Completed IS-195, Basic Incident Command System
- Participated as event coordinator for at least one major event
- Participated as shift supervisor for at least one major exercise

#### **Training Officer**

The Training Coordinator is responsible for the following:

- Manages the CARES Qualification Program
- Collaborates with the Operations Officer to identify and/or generate training events and opportunities to increase membership experience and proficiency in passing traffic.
- Coordinates personnel versed in or otherwise considered qualified in the presentation of those training materials
- Assists the Membership Coordinator in maintaining records indicating the level of training and skill proficiency of CARES members
- Assists the EC/RO in identifying topics and presenters of general or specific interest programs for the monthly Cupertino ARES general meetings

### **Information Security Officer**

The Information Security Officer (ISO) manages all aspects of CARES information security that is performed on behalf of our served agencies. The ISO is responsible for the following:

- Develops, implements, and maintains the information security procedures and policies for CARES
- Manages the information assets that are entrusted to CARES by Served Agencies
- Develops and delivers the necessary training to CARES
- Coordinates the audit of our information security procedures on an annual basis
- Coordinates the audit of our information assets on a quarterly basis
- In the absence of an assigned member, the EC/RO will assume this responsibility.

### **Technical Engineering Officer**

The Technical Engineering Officer ensures CARES is capable of performing its mission by maintaining the CARES communication equipment and assets in a state of readiness. Typical responsibilities of the Technical Engineering Officer include:

- Develops the equipment requirements and make recommendations based on the needs of the organization's served agencies
- Procures equipment needed to achieve the CARES mission
- Maintains CARES fixed and mobile communications systems and assets
- In the absence of an assigned member, the EC/RO will assume this responsibility.

### **Membership Officer**

This position maintains the records on CARES members. Typical responsibilities of the Membership Coordinator include

- Ensures the membership records are up to date
- Makes recommendations on member status changes
- Collects and processes new membership applications as necessary
- In the absence of an assigned member, the EC/RO will assume this responsibility.

---

## 2.4 DSWVP and City Insurance

This paragraph is an excerpt from the *Cupertino Volunteer Annex, 15-July-2021* and used as an introduction for this section.

*Volunteers, affiliated or unaffiliated, performing on behalf of the City will have injury and liability insurance while they operate in authorized activities they have been trained to do and are under supervision. The City has two ways of covering our volunteers—California State DSWVP and City Insurance. No volunteer activity is to be performed without insurance in place.*

### 2.4.1 Disaster Service Worker

A Disaster Service Worker (DSW) is any person who is registered with a Disaster Council for the purpose of engaging in disaster service without pay or other consideration, pursuant to the California Emergency Services Act. A Disaster Service Worker includes public employees, and any unregistered person pressed into service during a state of war, a state of emergency, or a local emergency by a person having authority to command the aid of citizens in the execution of his duties.



## 2.4.2 Disaster Service Worker Volunteer Program (DSWVP)

DSWVP provides compensation benefits to registered Disaster Service Worker (DSW) volunteers who are injured while participating in authorized disaster-related activities, including pre-approved training. Disaster service, as defined for the Program, is designed to aid in the response and recovery phases in a disaster or emergency. It does not include the day-to-day emergency response activities typically associated with, for example, law enforcement, fire services or emergency medical services. The Program also provides limited immunity from liability.

All CARES members must be registered as Cupertino Disaster Service Workers.

## 2.4.3 Who are Disaster Service Workers?

- Public employees or properly registered disaster volunteers
- City employees are mandated by law (CA Gov't Code Sec. 3100) to assist during a state of emergency.
- Volunteers who have registered in advance with their accredited local Disaster Council, executed a loyalty oath, and are dispatched for duty by competent authority during an emergency, e.g. "organized volunteers."
- Volunteers who are untrained and converge on the disaster scene with the intent of assisting are called "convergent" or "spontaneous untrained volunteers."
- A disaster service worker does not include any person registered as an active firefighting member or any regularly organized volunteer fire department.

## 2.4.4 City Insurance

The city provided self-funded insurance coverage for all volunteers (e.g.: Cupertino Citizen Corps, Parks and Rec, county MAC responders) for any city sponsored activity or event (4th of July, Big Bunny, fairs, festivals, training, meetings, C469 maintenance, etc.) where we are asked or approved to participate. Essentially, CARES uses city insurance for everything except declared emergencies.

All CARES members who are registered as Cupertino Disaster Service Workers are eligible for city insurance coverage.

---

## 2.5 Affiliations

CARES members hold dual membership in both the Amateur Radio Emergency Service and the Radio Amateur Civil Emergency Services organizations.

### 2.5.1 Amateur Radio Emergency Service

The Amateur Radio Emergency Service (ARES) is a field service of the American Radio Relay League (ARRL). Its members are licensed amateurs who have voluntarily registered their qualifications and equipment for communications duty in the public service when disaster strikes. Every licensed amateur, regardless of membership in ARRL or any other local or national organization is eligible for membership in ARES. Other than possessing an Amateur Radio license, the only qualification is a sincere desire to serve.

Because ARES is an amateur radio service, only licensed amateur radio operators are eligible for membership. The possession of emergency-powered equipment is desirable but is not a requirement for membership.

## 2.5.2 Radio Amateur Civil Emergency Services

The Radio Amateur Civil Emergency Services (RACES) is an emergency service function defined under Part 97 of the Federal Communication Commission (FCC) Rules. Both the Federal Emergency Management Agency (FEMA) and the State of California Governor's Office of Emergency Services (OES) sponsor RACES as an official volunteer organization.

RACES is a special phase of amateur radio operation that provides radio communication for civil preparedness purposes only, during periods of local, regional, or national civil emergencies. These emergencies are not limited to war-related activities, but can include natural disasters such as fires, floods, and earthquakes.

A RACES activation results from the declaration of an emergency by an authorized government official. Amateurs operating in a local RACES organization must be officially enrolled in that local civil preparedness group (such as CARES).

RACES operation is conducted by amateurs using their own primary station licenses, and by existing RACES stations. Operator privileges in RACES are dependent upon, and identified by, the class of license held in the Amateur Radio Service. All of the authorized frequencies and emissions allocated to the Amateur Radio Service are also available to RACES on a shared basis. But in the event that the President invokes his War Emergency Powers, amateur radio operators involved with RACES would be limited to certain frequencies (while all other amateur operation may be silenced) as specified in Part 97.407(b)(1).

While originally based on potential use for wartime, RACES has evolved over the years from addressing the needs of civil defense (which is also called civil preparedness) to encompassing all types of emergencies.

## 2.5.3 How ARES and RACES work together

Although RACES and ARES are separate entities, the ARRL advocates dual membership and cooperative efforts between both groups whenever possible.

The RACES regulations make it simple and possible for an ARES group whose members are enrolled in and certified by RACES to operate in an emergency with great flexibility. Using the same operators and the same frequencies, an ARES group that is also enrolled as RACES can "switch hats" from ARES to RACES and RACES to ARES to meet the requirements of the situation as it unfolds. For example, during a non-declared emergency, ARES members can operate under ARES, but when a state or federal authority declares an emergency, the operation can become RACES with no change in personnel or frequencies.

All registered CARES members hold dual membership in both ARES and RACES.

## 3 City Hazards

---

### 3.1 Introduction

The purpose of documenting the city hazards is to ensure that all CARES members understand the risks that exist in Cupertino and what to expect if a particular hazard were to manifest itself. This analysis is not exhaustive. However, it does identify the main hazards relevant to the CARES mission.

All members are strongly advised to read Cupertino General Plan, Chapter 7 “Health and Safety Element.” Attached in *Part 4 - References Section*, for a more complete description of Cupertino’s hazard assessment. Additional references are listed here where known.

---

### 3.2 Seismic Hazard – Earthquakes

#### 3.2.1 Description

The city is seismically very active. The mountains and lower foothills of Cupertino are crossed by the San Andreas Fault (that moves from side to side) and two shear faults: the Sargent-Berrocal and Monta Vista Fault systems (move up and down).

#### 3.2.2 History of Events

In 1989, The City experienced the Loma Prieta Earthquake, a 7.1 magnitude earthquake occurring on the San Andreas Fault south of Santa Clara Valley. Damage to the city was limited to toppled chimneys, one house fire, and one related fatality.

#### 3.2.3 Probability of occurrence

Loma Prieta was not viewed as the “big one.” It was a moderately strong earthquake but nowhere near the size of the San Francisco Earthquake of 1906.

In the report titled “Earthquake Outlook for the San Francisco Bay Region 2014-2043”, the USGS stated there is a 72% chance of an earthquake of magnitude 6.7 or greater striking somewhere in the San Francisco Bay region before 2043. Whereas the epicenter for the Loma Prieta Earthquake was centered in a sparsely populated area, the next one may be centered in a more populated area.

#### 3.2.4 City Reference

*The CUPERTINO [General Plan, Section 7, Health and Safety](#)*. See the subsection titled *Geologic and Seismic Hazards*.

---

## 3.3 Flood Hazard from Rain Storms

### 3.3.1 Description

Several streams and creeks flow through Cupertino, primarily from south to north in the direction toward the San Francisco Bay.

### 3.3.2 History of Events

As of 2003, Santa Clara Valley Water District (SCVWD) completed a series of stream and street crossing upgrades throughout the city. These efforts had a positive impact during subsequent year winter rains.

Prior to 2003, during the winter of 1998, several Cupertino creeks and streams overflowed their banks at several locations:

- Calabazas Creek at Prospect Avenue (in Saratoga). Flooding proceeded north into the intersection of Prospect Avenue and DeAnza Blvd.
- Calabazas Creek at Miller Avenue. Runoff from heavy rains overwhelmed the creek's capacity and spilled onto Miller Avenue flowing north onto Stevens Creek Blvd. Water was up to 2 feet deep in some locations. Minor flood damage occurred to the Fountainlet Apartments next to the creek.
- Calabazas Creek at Stevens Creek Blvd. Flooding also occurred at this location. Depressed parking areas across from JCPenney's at Valco Fashion Mall were under water.
- Stevens Creek at McClellan Road. Due to heavy spillage from the Stevens Creek Reservoir, the Stevens Creek overflowed at the Golf Course and Black Berry farm. McClellan Road was inundated and impassable in the vicinity of the creek crossing.

In previous years, other flooding events included:

- Overbanking at Calabazas Creek at Miller Ave: 1978, 1980, 1983, and 1986
- Sheet flooding at Stevens Creek at Stevens Creek Boulevard in 1986
- Extensive street flooding at Calabazas Creek at Miller Ave: 1983 and 1986
- Street flooding at Calabazas Creek at Bollinger Avenue in 1986 and 1998

### 3.3.3 Probability of Occurrence

The Santa Clara Valley Water District assessed the 1998 winter flooding as a "75 year" flood. Driven by El Nino' storms, this winter was considered unusual.

### 3.3.4 Population Affected

During the 1998 winter floods, some City residents with properties fronting overflowing creeks voluntarily left their homes. However, no shelters were established and residents returned to their homes within hours.

### 3.3.5 Adjacent Affected Jurisdictions

The bulk of Cupertino creeks and streams flow north into Santa Clara. Earlier flooding from the Calabazas Creek continued and overflowed its banks at Prune ridge Avenue between Tatau Avenue and Lawrence Expressway.

### 3.3.6 City Reference

*The CUPERTINO [General Plan, Section 7, Health and Safety](#)*. See the subsection titled Flood Hazards.

---

## 3.4 Flooding Hazard from Dam Failure

### 3.4.1 Description

Stevens Creek Dam is the only dam that affects the City of Cupertino. It is located in the Stevens Canyon south of Ricardo Road, is part of the Stevens Creek County Park, and owned by the Santa Clara Valley Water District. The reservoir is periodically inspected and the existing data about its capacity and endurance indicates a sound structure.

In the event of a dam failure, the estimated drainage of the Stevens Creek Dam would occur in one (1) hour 15 minutes depending on the size of the breach. The water would flow northeast, reaching Interstate-280 in 30 minutes. The main course of the water will flow through the Deep Cliff and Blackberry Farm Golf Courses until it reaches Stevens Creek Boulevard. There are few residences and businesses in this area. Once at Stevens Creek Boulevard, it will flow through the low-lying residential area of Phar Lap and the nearby streets and courts of the Oakdale Ranch subdivision.

Because of sound walls constructed on Freeways 85 and 280, the water will be prevented from flowing beyond them into Sunnyvale. The viaduct beneath Highway 85 descends into a 15" – 16" depression and will channel the water prior to it reaching Sunnyvale.

### 3.4.2 History of Events

While there has never been a breach of the dam since it was built, several improvements have been made over the last 25 years. These include:

- upgrade to an endurance level of 7.9 on the Richter scale in 1978
- small upstream and downstream berms created, dam was raised 10 feet in 1985
- upgraded by compacting dirt around the edges and across the face
- spillway upgraded to withstand a water flow of 15,600 cu ft per second

### 3.4.3 Probability of Occurrence

As stated in the "Stevens Creek Dam Failure Evacuation Plan," (June 7, 1993) an assessment of the dam's capacity and endurance are assuring and suggest that a dam failure is quite remote.

### 3.4.4 Population Affected

There is relatively little population in the areas that would be affected. There could be, however, seasonal shifts in the open-space recreation areas such as picnickers and golfers.

### 3.4.5 Adjacent Affected Jurisdictions

The possibility of the water inundating Sunnyvale is remote.

### 3.4.6 City Reference

1. [Stevens Creek Dam Plan](#), October 2012.
2. [The CUPERTINO General Plan, Section 7, Health and Safety](#). See the subsection titled Flood Hazards.

---

## 3.5 Wildland Fire Hazard

### 3.5.1 Description

CAL FIRE Battalion Three, supported by Santa Clara County Fire, operates in the State Responsibility Area (SRA) that includes Cupertino.

There are 16 square miles of land in the mountains of the Cupertino Planning Area, with people who live in the foothills and mountains being at the most risk from fire. Concerns for fire are mainly focused on the impact to the Stevens Creek watershed due to increased flooding and silting of streambeds.

While most residents living in urbanized areas are not exposed to high fire danger, recent California fires uncovered a greater risk when a fire is driven by high winds.

### 3.5.2 History of Events

On August 30, 2007, The Stevens Fire broke out in the hills west of the Cupertino in an unincorporated area of Santa Clara Valley. It burned through approximately 151 acres, prompting the voluntary evacuation of homes and vineyard facilities along Montebello Road. Firefighters from the Santa Clara County Fire Department, CAL FIRE and numerous other agencies worked to slow and eventually stop the spread of the fire.

Operations relied on a number of air assets including CAL FIRE helicopters and tankers that were able to effectively bolster fire lines established by hand crews and dozers. Additional fire suppression was offered through the first deployment of TANKER 910 (a DC-10) to a Northern California wildland fire incident.

More recently, the August 2020 CZU Lightning Complex fire in the Santa Cruz Mountains resulted in mandatory evacuation areas set within 7 miles of Cupertino. Heavy smoke blanketed the South Bay for several days making it unhealthy to go outdoors.

### 3.5.3 Probability of Occurrence

The California Department of Forestry and Fire Prevention identifies SRA Fire Hazard Severity Zones as Moderate, High, and Very High based on land, fuel loading, slope, and fire weather. Battalion Three is divided into 3 sections:

- the South Section (Loma Prieta area) is assessed to be a VERY HIGH
- the center section (West Santa Clara Valley Foothills) is MODERATE, and
- the North Section (Hwy 85 and I-280) is HIGH.

### 3.5.4 Population Affected

No estimates.

### 3.5.5 Adjacent Affected Jurisdictions

Saratoga, Los Altos, Los Altos Hills, various unincorporated areas of Santa Clara County.

### 3.5.6 City Reference

1. *The CUPERTINO [General Plan, Section 7, Health and Safety](#)*. See the subsection titled [Fire Safety](#).
2. *Cal Fire Strategic Fire Plan Santa Clara Unit, 2022*, See section titled [Battalion Three: \(West Santa Clara County\)](#)
3. [Santa Clara County Community Wildfire Protection Plan, 2023](#)

## 4 Overview of Operations

---

### 4.1 Introduction

The CARES response is based on the 5 operational phases:

1. Preparedness
2. Increased Readiness
3. Initial Response
4. Extended Response
5. Recovery

Each phase is characterized by a set of operational objectives that guide the organization in fulfilling its mission. While a set of general objectives exists, additional event-specific operational objectives may be defined as required.

During each phase, specific actions are taken to reduce or eliminate the impact of specific disaster situations. In coordination with the Planning/Intelligence Section Chief or the City's Emergency Preparedness Coordinator, the Cupertino EC/RO will determine the appropriate level of alert for CARES.

---

### 4.2 Standing Orders

An earthquake occurrence requires special consideration given the uncertainty of timing, availability of city staff, and the magnitude of the resulting damage. The ability for CARES to quickly activate will help the city develop its Common Operating Picture that will guide the city's ultimate response. As a result, authorization to auto-activate is incorporated into the Cupertino Emergency Operations Plan (2005):

*"During self-announcing natural disasters, CARES members may self-dispatch and commence windshield surveys to provide situation status and preliminary safety assessments, provided it is safe to do so. CARES members will not respond to manmade disasters unless authorized by the EOC Director."*

To this end, the following Standing Orders for a CARES response are in effect:

**Standing Order #1**

On detection of an Earthquake with a Modified Mercalli Index (MMI) of 6 or greater, initiate Increased Readiness Operations/Earthquake and, at the discretion of the EC or designee, initiate Initial Response Operations.

**Standing Order #2**

At the request of the Cupertino OES, initiate Initial Response Operations for all other emergencies.

---

### 4.3 Operational Phases

#### 4.3.1 Preparedness

Preparedness is the operational phase in which CARES members will spend the bulk of our time. It is best characterized as a period when no emergency situation exists or is imminent.

The operational objectives for this phase are:

1. CARES members work to develop or maintain the skills and understanding needed to support an emergency response.
2. CARES members are aware of new or changing hazards and conditions in the city.

CARES will take advantage of this time for planning, training, and practice with CARES members participating as time, expertise, and interest allow.

Activities to support the Preparedness Operational Objectives may include, but are not limited to:

- Conducting the weekly CARES Emergency Net
- Holding technical, emergency preparedness, and operational training sessions
- Conducting drills and exercises to test response scenario processes
- Holding monthly general membership meetings
- Supporting non-emergency activities (parades, special events, etc.) to test our abilities

#### 4.3.2 Increased Readiness / General

The operational objectives for this phase are:

1. All CARES members are alerted and ready to respond.
2. CARES members are kept up to date on changes and developments regarding the potential emergency.
3. The City and our Served Agencies are supported as requested.

On receiving a warning, or observing that an emergency situation is imminent or likely to occur soon, or at the request of the City, the EC/RO or his designate will initiate actions to increase the readiness of CARES. Events that may trigger Increased Readiness Operations include:

- Earthquakes: Early warning of an earthquake by the USGS or another agency.
- Flooding: CARES may receive some notification or indication that flooding is imminent. The National Weather Service, through the services of the Emergency Alert System, is responsible for Flash Flood warnings and will notify the public of potential flooding danger.
- Dam Failure: The City may receive some notification or indication that a dam failure is imminent. The Santa Clara Valley Water District operates various measurement devices to detect sudden changes in water levels or slides on the dam surface. The response to a dam failure must be fast. Depending on the time and day of the week, CARES may be called to increase our state of readiness.
- Wildland Fire: CARES may receive some notification or indication that a fire danger to the city is imminent. This notification will come from Cupertino OES, the Cupertino EOC, or commercial news outlets.
- Other: Other natural or civil event warranting emergency communications.

Activities to support the Increased Readiness Operational Objectives may include, but are not limited to:

- Notifying CARES members of the emergency and a potential activation
- Reviewing specific hazard operating procedures
- Performing personal and City equipment readiness checks
- Activating the Cupertino Emergency Net for information-sharing

#### 4.3.3 Increased Readiness / Earthquake

The operational objectives for this phase are:

1. Determine the magnitude of the earthquake using the Modified Mercalli Index (MMI).
2. Evaluate the need to initiate Initial Response Operations.

Activities to support the Increased Readiness/Earthquake operational objectives may include, but are not limited to:

- Activating the Cupertino Emergency Net
- Take check-ins and MMI reports
- Check for field responder availability
- For an average Mike-Mike reports score of **6 or greater**, execute Initial Response Operations.

#### 4.3.4 Initial Response / Activation

The operational objectives for this phase are:

1. CARES is formally activated.



2. The Incident Action Plan is developed with elements from the CARES Task List and guides the response.

The CARES activation and initial response is triggered by either:

1. the occurrence of an Earthquake (auto-activation), or
2. a local declaration of emergency by the City's Director of Emergency Services. This activation may take place before, during, or immediately after an emergency situation occurs.

The CARES Initial Response will most likely take place in the field.

Based on the response requirements, activities to support the Initial Response Operational objectives may include, but are not limited to:

- Notify all CARES members of the existence of an emergency
- Activate the Cupertino Emergency Net
- Check into the Cupertino Emergency Net; pass traffic as required
- For an earthquake event:
  - initiate the PSA
  - collect PSA reports, pass to the EOC
- Deploy Comm 469 to the EOC and staff
- Determine the availability of CARES members for a field assignment
- Depending on staffing and response requirements,
  - make field assignments to City ARKs, Activate to ARK Level 2
  - make field assignments to SCCFD Fire Stations
  - initiate the Infrastructure Safety Assessment procedure; collect and transmit results to Served Agencies

#### 4.3.5 Extended Response

The operational objectives for this phase are:

1. CARES provides the city and its served agencies with the necessary communications needed to support the city during a prolonged emergency response.
2. The CARES resource and staffing plan is developed.
3. CARES members receive the logistical support needed to fulfill their mission.

The bulk of the CARES extended response will take place in the field. An extended response operation involves coordinating and managing CARES resources and assets to help mitigate an emergency situation and support the City's transition to Recovery Operations.

CARES will continue to operate under the authority of and report to the City's Planning/Intelligence Section Chief. When the Cupertino EOC is activated, amateur radio communication and coordination will be established between CARES field personnel and the EOC. Comm 469 must be staffed to support emergency communications tasks.

Activities to support the Extended Response Operational Objectives may include, but are not limited to:

- Developing requirements for CARES staffing
- Staffing and maintaining the Net Control Operator position
- Participating in or reporting detailed damage assessments
- Supporting City ARKs, mass care, or other facilities with emergency communications
- Staffing creek-watch stations and reporting on any changes
- Supporting served agencies with emergency communications
- Prioritizing, allocating, directing, and tracking CARES resources
- Procuring additional resources to sustain operations
- Participating in County resource and command nets

#### 4.3.6 Recovery / Demobilization

The operational objectives for this phase are:

1. CARES has accomplished its assigned mission and is directed to demobilize.

Recovery activities are mainly executed by the City and involve restoring services to the public and rebuilding affected areas.

As the immediate threat to life, property, and the environment subsides and standard communication systems are brought back on line, CARES may be demobilized in part or in its entirety. While a demobilization does not necessarily mean total disengagement, it does mean that the CARES formal involvement is complete. As Cupertino resident volunteers, CARES members are encouraged to participate in the recovery in a way that suits each individual.

Activities to support the CARES Recovery Operational Objectives may include, but are not limited to:

- Performing any replenishment and maintenance on City and personal equipment
- Assisting neighbors, relief agencies, or the city in non-communications recovery activities
- Collect event documentation; Collect all records and forms; develop the after-action report; submit to City EOC Planning Section, Documentation Unit.

## 5 Served Agencies

---

### 5.1 Introduction

This section describes the served agencies with which CARES has a formal agreement. For each listed agency, specific agency requirements relevant to CARES are described followed by the type of response CARES can make to address that requirement. Copies of all agreements are included in *Part 4 References Section*.

---

### 5.2 City of Cupertino

#### 5.2.1 Background

The City of Cupertino (2021 set pop. 58,622) is an incorporated municipality in the County of Santa Clara. It is located between Los Altos and Sunnyvale on the north, Santa Clara and San Jose on the eastern flank, and Saratoga and portions of San Jose on the south. The Santa Cruz Mountains are on the westerly fringe. The City delivers access, utility, and public safety services to its residents either directly or through contract service provider organizations. The City is responsible for establishing the City's emergency plan and ensuring city departments are prepared to respond when called to do so. The City Manager is responsible for activating the emergency plan in accordance with the appropriate emergency ordinance and assumes the role of Director of Emergency Services. The City will manage all emergencies and disasters using the Incident Command System (ICS) within the structure of the Standardized Emergency Management System (SEMS).

#### 5.2.2 Requirements for an Earthquake

As part of the INITIAL RESPONSE, the City's Director of Emergency Services needs accurate and timely information immediately after a citywide event in the form of a damage and casualty assessment to understand the extent of the damage and decide where city resources should be deployed first. In the case of the 1989 Loma Prieta earthquake, a preliminary damage assessment was not completed until several hours after the initial event.

For the EXTENDED RESPONSE, the city is expected to handle the local situation with its own services and resources as best possible. The city has also promoted a strong Cupertino Citizen Corp that represents Amateur Radio (CARES), CERT, and Medical Reserve Corps (MRC) volunteers. When it becomes clear that a specific service or capability (such as medical, shelter, material) can no longer cope with the demands for assistance, the city will then request help from the Operational Area. The city needs timely information on the state of service and relief providers to know when this situation is about arise.

##### **CARES Response**

1. To support an INITIAL RESPONSE, CARES members will perform a preliminary damage assessment of their local neighborhoods and report that information to the city through the CARES Emergency Net. Because of the geographic dispersion of CARES members throughout the city, this early assessment may be considered representative of the damage throughout the entire city.
2. To support an EXTENDED RESPONSE, CARES members may be dispatched into the field to fill communications positions at City-sponsored ARC sites (area CERT locations) as well as for agencies and relief providers that typically do not have communications capabilities.
3. Additionally, because Cupertino residents may seek out help at city and county facilities (such as ARKS, fire stations, etc.), CARES members may be dispatched to these locations to collect data and report on the status of Cupertino residents.

### 5.2.3 Requirements for Flooding by Severe Weather

Because the Santa Clara Valley Water District does not release flood watch or warning bulletins (this function is performed by National Weather Service), the city needs reliable and timely information on the levels of local creeks and streams during severe storms to determine if a city response to flooding is required.

**CARES Response:**

1. To support a state of INCREASED READINESS or an INITIAL RESPONSE, CARES members may be asked to establish a creek-watch net and monitor the levels of specific creeks and streams at specific city intersections.
2. If flooding occurs and residents are displaced from their homes, CARES members may be dispatched to staff communication positions at shelters or other locations as part of an EXTENDED RESPONSE.

### 5.2.4 Requirements for Flooding by a Dam Failure

The Stevens Creek Dam is remotely monitored for any change in water level. In the event that a dam failure is imminent, the city will require residents in the inundation area to be immediately notified. The Santa Clara County Sheriff's Department will manage the notification process.

**CARES Response:**

1. If flooding occurs and residents are displaced from their homes, CARES members may be dispatched to staff shelters or positions at other volunteer response team locations as part of an EXTENDED RESPONSE.

### 5.2.5 Requirements for Fire

While Santa Clara County Fire or CAL FIRE undoubtedly will have jurisdiction over any wild land fire that may put Cupertino at risk, the city will want to understand the state of the event, the risk to the community, and progress toward its containment.

**CARES EXTENDED Response:**

1. Support an Ember Watch throughout the city.
2. Deploy a cross-band repeater to reach the western portion of the City (west of Coyote Ridge).
3. During the Stevens Fire, CARES was asked to provide a radio link to Fire responders in the field to the EOC due to poor cell phone coverage in the affected area.

---

## 5.3 Santa Clara County Fire Department

### 5.3.1 Background

The Santa Clara County Fire Department is a California Fire Protection District serving Santa Clara County and the communities of Campbell, Cupertino, Los Altos, Los Altos Hills, Los Gatos, Monte Sereno, Morgan Hill, Saratoga, and the unincorporated areas adjacent to these cities with ISO Class 2/8 services. The Department operates 3 stations in Cupertino – Cupertino Station, Monta Vista Station, and Seven Springs Station – with 24x7 full time staffing. On activation of the City’s emergency plan, a Department representative responds to the EOC and supports the city as a member of the Operations Section.

### 5.3.2 General Requirements

As part of any INITIAL RESPONSE, the Fire Department will dispatch its units based on priorities established by County Fire Command. An accurate assessment of the city’s state will be imperative for helping County Fire prioritize its response.

For the EXTENDED RESPONSE, County Fire may be expected to manage incoming fire equipment assets from distant departments. These assets would be staged and deployed based on the overall operational plan. The ability to coordinate these assets will be critical to ensure an effective response.

Additionally, a large contingent of County Fire personnel lives outside the area with some County Fire personnel traveling up to hundreds of miles from their home to work their shift. During an EXTENDED RESPONSE, the ability to provide a health and welfare check for on-shift personnel of their families will help County Fire personnel focus on the task at hand.

#### **CARES EXTENDED Response:**

1. CARES members may be dispatched to fire equipment staging areas and response areas. The mission may be to help coordinate the movement of equipment and material throughout the response area, and provide status in the forms of personal observations to the EOC.
2. Because Cupertino residents may seek out help at city and county facilities (such as ARKs, fire stations, etc.), CARES members may be dispatched to Fire Stations in Cupertino to collect data and report on the status of Cupertino residents.
3. CARES will use the County RACES voice or packet networks to pass health and welfare traffic on behalf of County Fire personnel.

---

## 5.4 Cupertino Sanitary District

### 5.4.1 Background

The Cupertino Sanitary District (CuSD) is a Special District that provides service to over 50,000 persons with more than 23,000 residences and homes within the City of Cupertino, portions of the Cities of Saratoga and Los Altos, and surrounding unincorporated areas.

CuSD owns and manages over 1 million lineal feet of sewer mains, 0.5 million lineal feet of sewer laterals, 17 pump stations, 4,000 manholes and flushing inlets, and one equipment storage facility. CuSD conveys nearly 5 million gallons of wastewater daily from its customers for treatment at the San Jose/Santa Clara Water Pollution Control Plant.

CuSD is chartered to provide a safe, effective and economical sewerage system for the above areas. The CuSD is responsible for establishing the Cuds' Emergency Plan and preparations to respond when called to do so. The District Manager-Engineer, or his designee, is responsible for activating the Emergency Plan in accordance with the appropriate emergency guidelines. The CuSD will manage a disaster response to protect its assets using the CuSD Emergency Plan.

One component to the sanitary system are pump stations. While the Valley has a gentle slope to the bay, there are locations where pumps are required to pump sewage over high points or return the flow to a reasonable depth for the sewage to be on its way again. These pump stations cycle on to empty "wet wells" whenever the sewage levels reach a certain point.

### 5.4.2 General Requirements

As part of an INITIAL RESPONSE, CuSD staff will confirm the stability of the sanitary system in Cupertino.

For an EXTENDED RESPONSE, any loss of electrical power to the pump stations may result in a spill onto city streets. Most of the CuSD pump stations have permanently mounted generators that will switch on automatically in the event of a power loss. CuSD also owns and operates several portable generators. During a power loss, up to 4 crews of CuSD Field Inspectors would be deployed with portable generators to check on wet well levels and apply power to the pumps as required.

**CARES Response:**

1. To support an EXTENDED RESPONSE, CARES will perform an Infrastructure Safety Assessment of CuSD assets as soon as possible after an infrastructure-impacting event, or when requested and resources permitting, and report our observations to CuSD on their assets.

---

## 5.5 San Jose Water Company

### 5.5.1 Background

San Jose Water Company (SJWC) is an investor-owned public utility in the business of providing water service to approximately one million people in the cities of San Jose, Los Gatos, Monte Sereno, Saratoga, Campbell and Cupertino through systems acquired under lease, purchase, or franchise agreements.

SJWC service area covers about 140 square miles in the Santa Clara Valley with water sourced from groundwater (wells, ~40%), imported surface water (supplied by the Santa Clara Valley Water District, ~50%), and local mountain surface water (Santa Cruz Mountain watershed, ~10%). Water supplied to the City of Cupertino originates from both import and groundwater.

SJWC is responsible for establishing their emergency plan. The company operates during emergencies in accordance with emergency guidelines established in the plan.

### 5.5.2 General Requirements

As part of an INITIAL RESPONSE, SJWC staff will confirm the stability of the water delivery system throughout their operating area. Assistance to inspect of storage facilities and distribution lines may be requested to the Cupertino EOC.

For an EXTENDED RESPONSE, SJWC requests periodic inspection or monitoring, and reporting of critical assets.

**CARES Response:**

1. To support an EXTENDED RESPONSE, CARES will perform an Infrastructure Safety Assessment of SJWC assets as soon as possible after an infrastructure-impacting event, or when requested and resources permitting, and report our observations to SJWC on their assets.